

ESQUEMA LOCALIZACIÓN

PLANTA 1ª

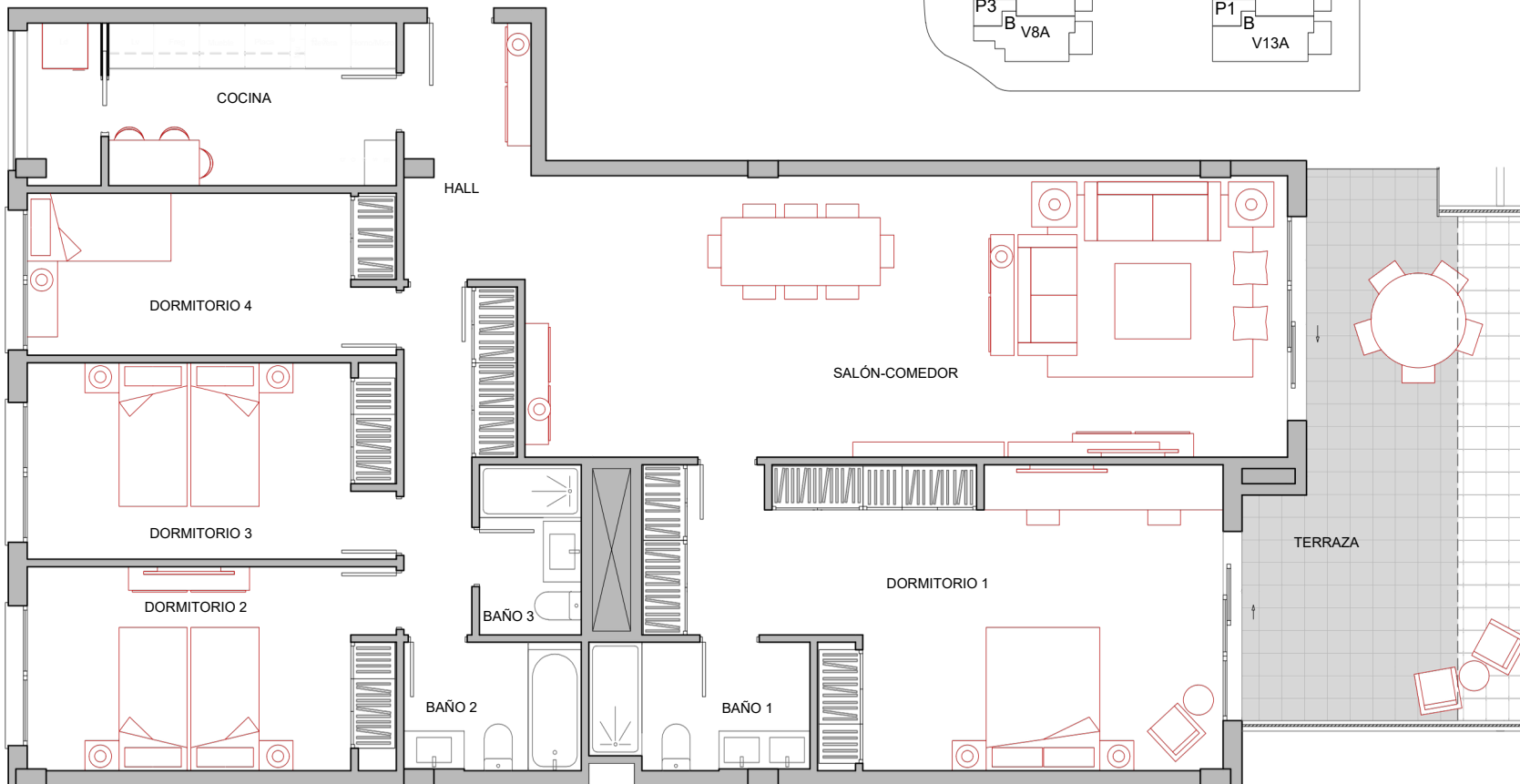

| VIVIENDA VT10A | |
|--|-----------------------|
| Superficies Construidas Aproximadas | |
| Vivienda | 147.90 m ² |
| Zona exterior | 25.25m ² |
| Total * | 189.95m ² |
| Superficies Útiles Aproximadas | |
| Salón-Comedor | 37.35m ² |
| Cocina | 8.15 m ² |
| Hall | 5.60 m ² |
| Distribuidor | 5.50 m ² |
| Dormitorio 1 | 26.80m ² |
| Dormitorio 2 | 13.00m ² |
| Dormitorio 3 | 12.60m ² |
| Dormitorio 4 | 10.40m ² |
| Baño 1 | 4.85 m ² |
| Baño 2 | 4.00 m ² |
| Baño 3 | 3.00 m ² |
| Superficie Útil Interior | 131.25m ² |
| Tendedero | 2.00 m ² |
| Terraza | 23.40m ² |
| Superficie Útil Exterior | 25.40m ² |
| Superficie Útil (Dec. 218/2005) | 143.95m ² |

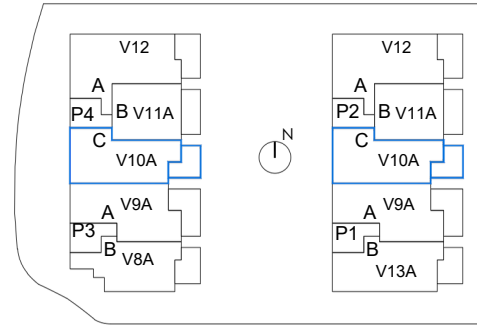