

ESQUEMA LOCALIZACIÓN PLANTA 3ª

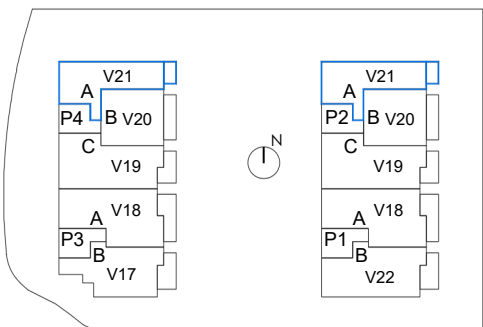

 Terraza cubierta



VIVIENDA VT21	
Superficies Construidas Aproximadas	
Vivienda	120.50m ²
Zona exterior	33.40 m ²
Total *	168.80m ²
Superficies Útiles Aproximadas	
Salón-Comedor-Cocina	35.25 m ²
Hall	11.90 m ²
Distribuidor	4.10m ²
Dormitorio 1	17.75 m ²
Dormitorio 2	13.50 m ²
Dormitorio 3	10.40 m ²
Baño 1	4.55m ²
Baño 2	4.00m ²
Baño 3	3.75m ²
Superficie Útil Interior	105.20m ²
Terraza 1	11.05 m ²
Terraza 2	18.55 m ²
Superficie Útil Exterior	29.60 m ²