

ESQUEMA LOCALIZACIÓN

PLANTA 3ª

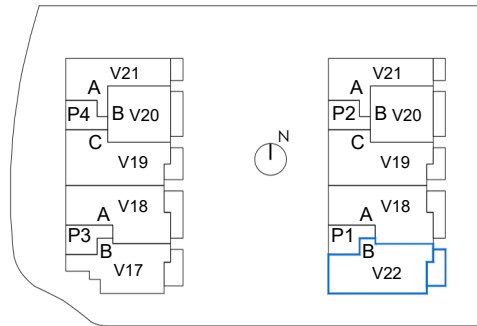

VIVIENDA VT22	
Superficies Construidas Aproximadas	
Vivienda	113.30m ²
Zona exterior	14.90m ²
Total *	140.60m ²
Superficies Útiles Aproximadas	
Salón-Comedor-Cocina	33.50m ²
Hall	7.25m ²
Distribuidor	1.60m ²
Dormitorio 1	18.60m ²
Dormitorio 2	13.05m ²
Dormitorio 3	13.10m ²
Baño 1	5.20 m ²
Baño 2	4.10m ²
Aseo	2.60m ²
Superficie Útil Interior	99.00m ²
Terraza	13.30m ²
Superficie Útil Exterior	13.30m ²
Superficie Útil (Dec.218/2005)	105.65 m ²

