

ESQUEMA LOCALIZACIÓN

PLANTA 3ª

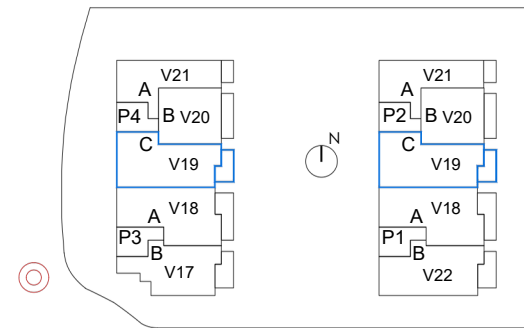

VIVIENDA VT19

Superficies Construidas Aproximadas

Vivienda	140.90 m <sup>2</sup>
Zona exterior	15.85m <sup>2</sup>
Total *	171.90m <sup>2</sup>

Superficies Útiles Aproximadas

Salón-Comedor	34.00m <sup>2</sup>
Cocina	8.15 m <sup>2</sup>
Hall	5.55 m <sup>2</sup>
Distribuidor	5.50 m <sup>2</sup>
Dormitorio 1	23.15m <sup>2</sup>
Dormitorio 2	13.05m <sup>2</sup>
Dormitorio 3	12.60m <sup>2</sup>
Dormitorio 4	10.35m <sup>2</sup>
Baño 1	4.85 m <sup>2</sup>
Baño 2	4.00 m <sup>2</sup>
Baño 3	3.00 m <sup>2</sup>

Superficie Útil Interior	124.20m <sup>2</sup>
--------------------------	----------------------

Tendedero	2.00 m <sup>2</sup>
-----------	---------------------

Terraza	14.50m <sup>2</sup>
---------	---------------------

Superficie Útil Exterior	16.50m <sup>2</sup>
--------------------------	---------------------

Superficie Útil (Dec.218/2005)	132.45m <sup>2</sup>
--------------------------------	----------------------

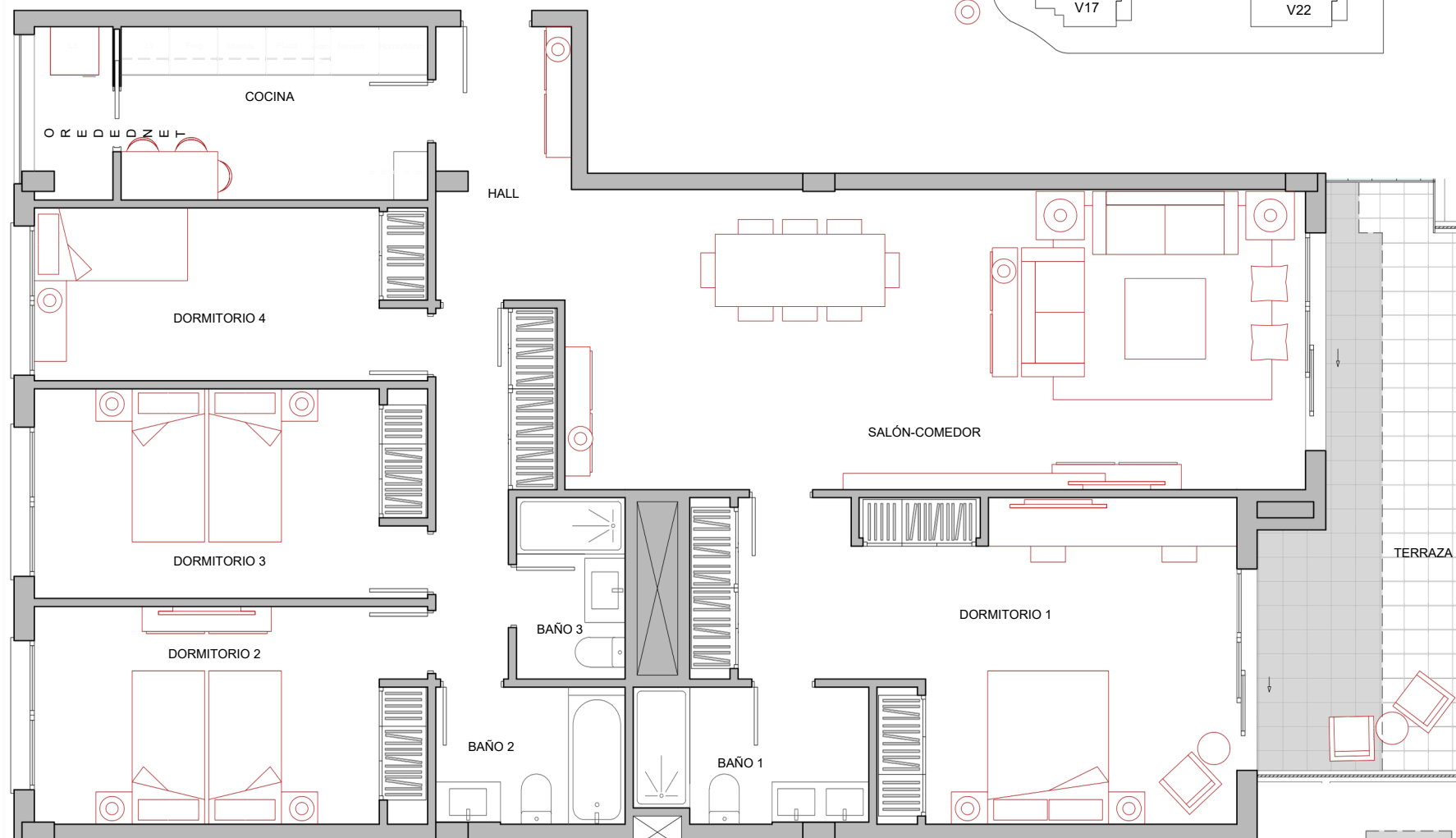

Terraza cubierta

Ed: Abril de 2024