

ESQUEMA LOCALIZACIÓN

PLANTA 4ª

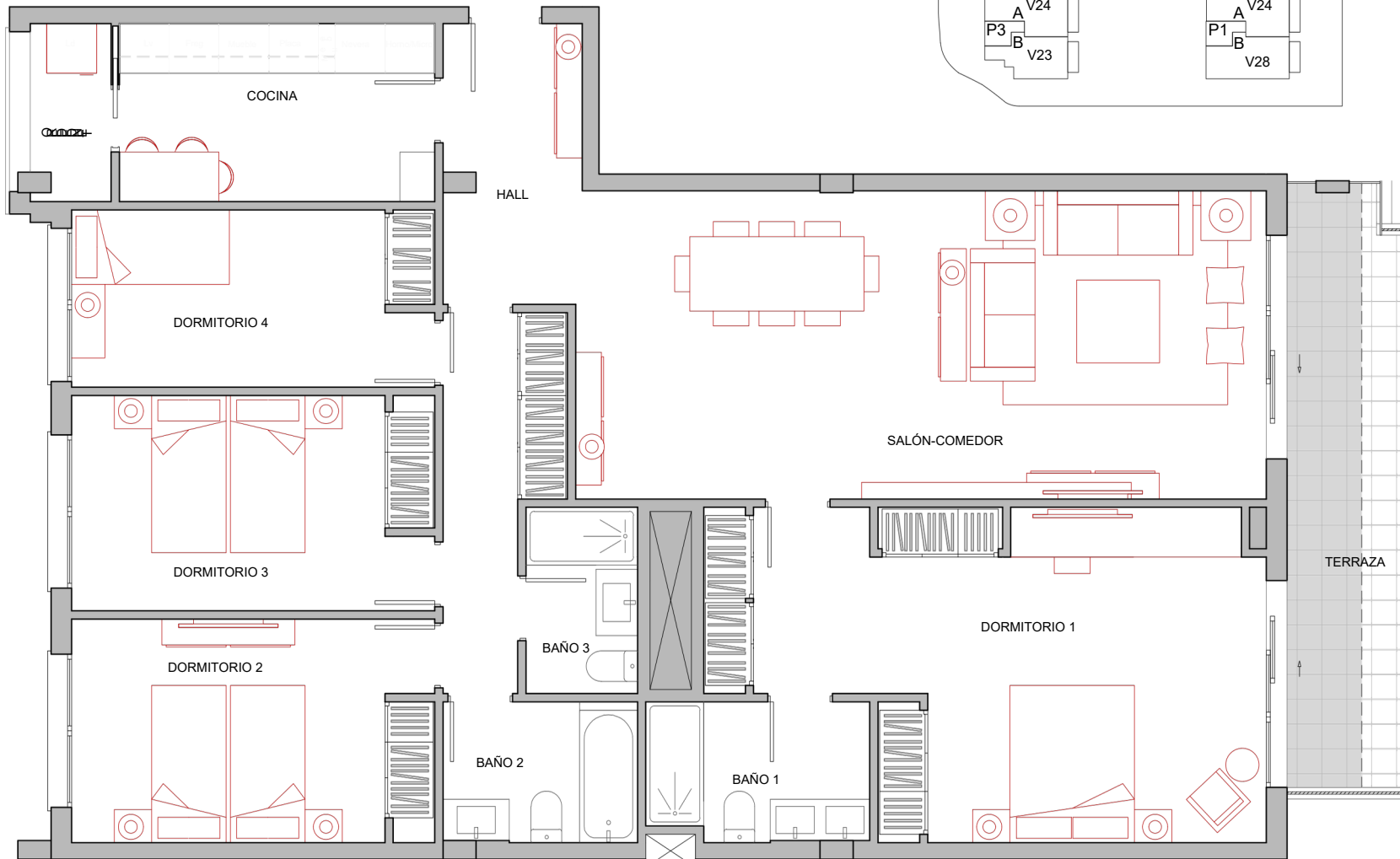

VIVIENDA VT25	
<b>Superficies Construidas Aproximadas</b>	
Vivienda	133.35 m <sup>2</sup>
Zona exterior	11.40m <sup>2</sup>
Total *	158.80m <sup>2</sup>
<b>Superficies Útiles Aproximadas</b>	
Salón-Comedor	30.95m <sup>2</sup>
Cocina	8.15 m <sup>2</sup>
Hall	5.45 m <sup>2</sup>
Distribuidor	5.50 m <sup>2</sup>
Dormitorio 1	23.45m <sup>2</sup>
Dormitorio 2	11.70m <sup>2</sup>
Dormitorio 3	11.30m <sup>2</sup>
Dormitorio 4	9.30 m <sup>2</sup>
Baño 1	4.45 m <sup>2</sup>
Baño 2	4.00 m <sup>2</sup>
Baño 3	3.00 m <sup>2</sup>
Superficie Útil Interior	117.25m <sup>2</sup>
Tendedero	2.00 m <sup>2</sup>
Terraza	10.10m <sup>2</sup>
Superficie Útil Exterior	12.10m <sup>2</sup>
Superficie Útil (Dec.218/2005)	123.30m <sup>2</sup>

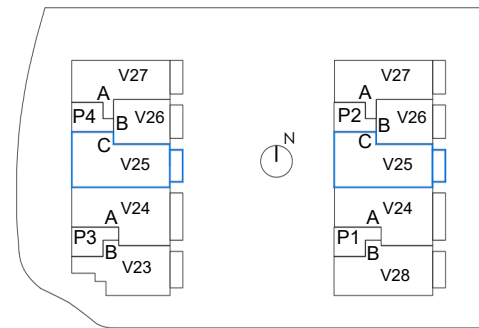

Terraza cubierta

Ed: Abril de 2024